

# ICT

BY UNILUX

Industrial Condensing Technology

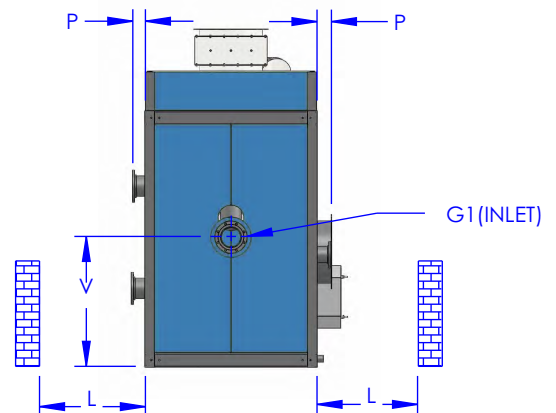

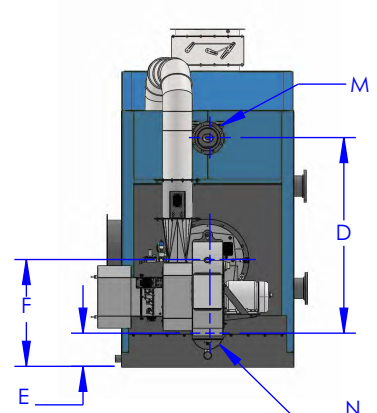
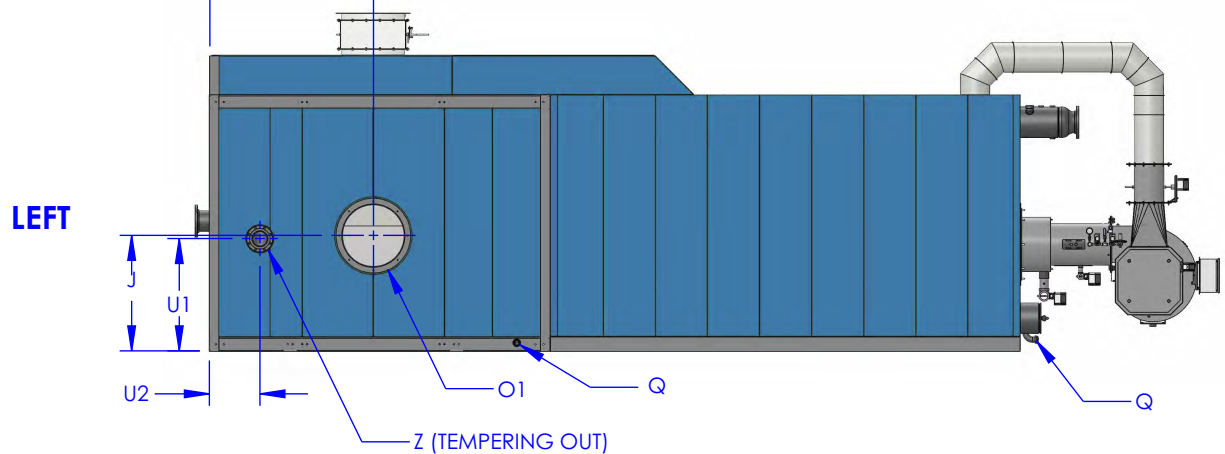
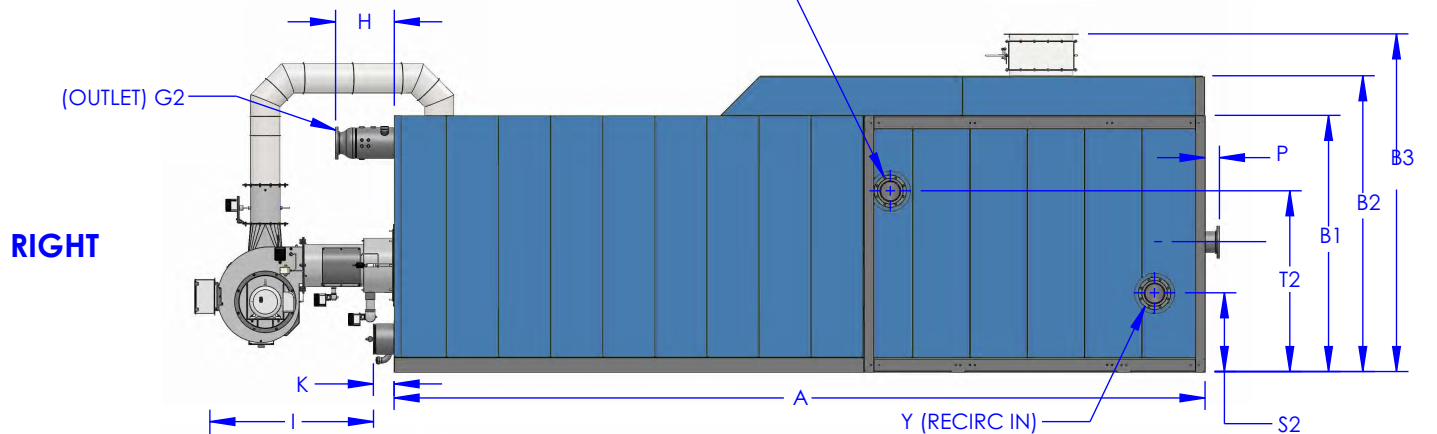
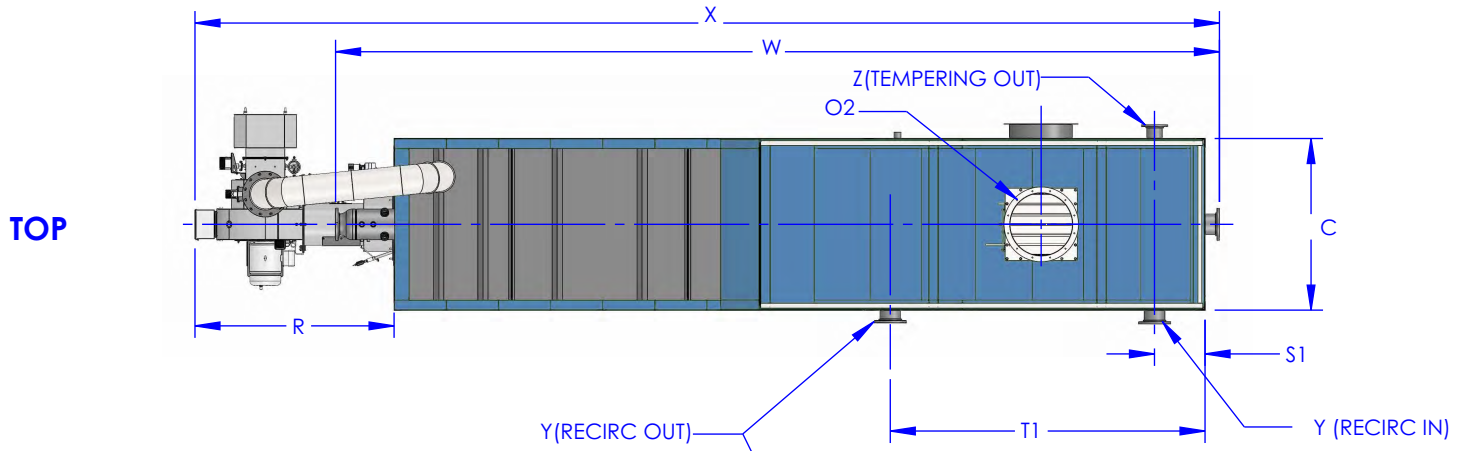

**FRONT**

**REAR**

	BOILER MODEL - ICT	1200	1400	1600	1800	2000
A	BOILER BASE LENGTH	317 7/8	332 7/8	344 7/8	352 7/8	341 7/8
B1	BOILER HEIGHT	99	99	101	106 1/2	106 1/2
B2	BOILER HEIGHT TO TRANSITION	115 3/8	115 3/8	119 3/8	124 7/8	122 7/8
B3	BOILER OVERALL HEIGHT TO BYPASS DAMPER	131 3/16	132 3/16	134	140 11/16	140 3/4
C	BOILER BASE WIDTH	55 1/2	55 1/2	59 1/2	65 1/2	71 1/2
D	BOILER DRUMS CENTER-TO-CENTER	74	74	76	81 1/2	81 1/2
E	CENTER OF LOWER DRUM TO BOTTOM	14	14	14	14	14
F	CENTER OF BURNER OPENING TO BOTTOM	41	41	41	44 1/2	44 1/2
G1	BOILER INLET FLANGE, CLASS 150	6	8	8	8	8
G2	BOILER OUTLET FLANGE, CLASS 150	6	8	8	8	8
H	NOZZLE CLEARANCE FROM TOP FRONT	20 1/4	23 1/8	23 1/8	23 1/8	23 1/8
I	CENTER COND. FLUE/ BYPASS FLUE OUTLETS TO REAR	79 7/8	79 7/8	84 5/16	87 7/8	72 3/8
J	CENTER COND. FLUE OUTLET TO BOTTOM	38 1/8	38 1/8	46 1/8	51 5/8	48 1/8
K	DRUM CLEARANCE FROM BASE	8 5/8	8 5/8	8 5/8	8 5/8	8 5/8
L	TUBE PULL CLEARANCE - BOTH SIDES	38	38	42	48	54
M	UPPER DRUM O.D., NPS	12 3/4	12 3/4	12 3/4	12 3/4	12 3/4
N	LOWER DRUM O.D., NPS	12 3/4	12 3/4	12 3/4	12 3/4	12 3/4
O1	FLUE GAS OUTLET, I.D.	24	24	26	26	26
O2	BYPASS FLUE GAS OUTLET, I.D.	22	24	24	26	26
P	RECIRC / TEMPERING FLANGE CLEARANCE FROM SIDE	6	6	6	6	6
Q	DRAIN CONNECTION (2) - NPT	2	2	2	2	2
R	BURNER DIMENSION (EST)	58 3/8	58 3/8	66 7/8	66 7/8	69 5/8
S1	RECIRC INLET TO REAR	26 3/4	26 3/4	26 11/16	25 3/4	25 1/16
S2	RECIRC INLET TO BOTTOM	28 3/8	32 13/16	32 13/16	32 13/16	32 7/8
T1	RECIRC OUTLET TO REAR	149 1/4	149 1/4	149 1/8	156 1/8	136 1/16
T2	RECIRC OUTLET TO BOTTOM	71 13/16	71 13/16	71 13/16	75 5/16	77 5/16
U1	TEMPERING OUTLET TO BOTTOM	39 11/16	46 13/16	46 13/16	46 13/16	46 7/8
U2	TEMPERING OUTLET TO REAR	26 3/4	26 3/4	26 11/16	25 3/4	25 1/16
V	BOILER INLET TO BOTTOM	46	45	51 1/8	56 9/16	54 1/8
W	OVERALL BOILER LENGTH	344 1/8	362	374	382	371
X	OVERALL BOILER LENGTH WITH BURNER	382 5/16	397 1/4	417 3/4	425 3/4	417 1/2
Y	RECIRC INLET/ OUTLET FLANGE, CLASS 150	6	6	6	8	8
Z	TEMPERING OUTLET FLANGE, CLASS 150	4	6	6	6	6

	BOILER MODEL - ICT	2500	2900	3000	3500
A	BOILER BASE LENGTH	378 3/8	416 1/16	434 1/2	470 1/2
B1	BOILER HEIGHT	129 7/16	135 3/8	147 1/2	157 1/2
B2	BOILER HEIGHT TO TRANSITION	149 11/16	155 1/2	167 5/8	177 5/8
B3	BOILER OVERALL HEIGHT TO BYPASS DAMPER	163 1/2	170 3/8	182 3/4	192 1/2
C	BOILER BASE WIDTH	84	84	102	102
D	BOILER DRUMS CENTER-TO-CENTER	98	104	115	125
E	CENTER OF LOWER DRUM TO BOTTOM	15 1/2	15 1/2	15 3/8	17 1/2
F	CENTER OF BURNER OPENING TO BOTTOM	52	54 1/4	59	61
G1	BOILER INLET FLANGE, CLASS 150	10	10	10	12
G2	BOILER OUTLET FLANGE, CLASS 150	10	10	10	12
H	NOZZLE CLEARANCE FROM TOP FRONT	30 7/8	30 7/8	41 7/16	42 3/16
I	CENTER COND. FLUE/ BYPASS FLUE OUTLETS TO REAR	95 5/8	106 7/8	106 7/8	115 3/8
J	CENTER COND. FLUE OUTLET TO BOTTOM	71 3/16	76 13/16	89 3/16	95 1/4
K	DRUM CLEARANCE FROM BASE	11 5/16	11 5/8	28 1/8	29 1/8
L	TUBE PULL CLEARANCE - BOTH SIDES	70	70	76	76
M	UPPER DRUM O.D., NPS	16	16	16	16
N	LOWER DRUM O.D., NPS	16	16	16	16
O1	FLUE GAS OUTLET, I.D.	26	26	26	26
O2	BYPASS FLUE GAS OUTLET, I.D.	28	30	30	32
P	RECIRC / TEMPERING FLANGE CLEARANCE FROM SIDE	6	6	6	6
Q	DRAIN CONNECTION (2) - NPT	2	2	2	2
R	BURNER DIMENSION (EST)	69 5/8	69 5/8	78 1/4	78 1/4
S1	RECIRC INLET TO REAR	29 7/8	29 1/8	29 1/8	34
S2	RECIRC INLET TO BOTTOM	39 1/8	38 7/8	38 7/8	45 1/2
T1	RECIRC OUTLET TO REAR	159 5/16	183 13/16	187 5/8	196 1/2
T2	RECIRC OUTLET TO BOTTOM	89 5/8	95 7/16	106 3/8	118 1/2
U1	TEMPERING OUTLET TO BOTTOM	56 1/8	55 7/8	55 7/8	65 1/2
U2	TEMPERING OUTLET TO REAR	29 7/8	29 1/8	29 1/8	34
V	BOILER INLET TO BOTTOM	75 1/8	80 3/4	93 1/8	99 1/2
W	OVERALL BOILER LENGTH	415 1/4	452 15/16	481 15/16	518 11/16
X	OVERALL BOILER LENGTH WITH BURNER	454	491 11/16	518 3/4	554 3/4
Y	RECIRC INLET/ OUTLET FLANGE, CLASS 150	10	10	10	10
Z	TEMPERING OUTLET FLANGE, CLASS 150	8	8	8	10



**Industrial Condensing Technologies**

**ICT CONDENSING HOT WATER BOILER CAPACITY RATINGS**

<b>BOILER MODEL NO.</b>	<b>HIGH FIRE INPUT</b>	<b>HIGH FIRE OUTPUT NATURAL GAS FIRED</b>	<b>APPROX. BHP NATURAL GAS</b>	<b>HIGH FIRE OUTPUT NO. 2 OIL FIRED</b>	<b>APPROX. BHP NO. 2 OIL</b>
ICT 1200W	12 000 MBH	11 220 MBH	335 BHP	10 560 MBH	315 BHP
ICT 1400W	14 000 MBH	13 090 MBH	391 BHP	12 320 MBH	368 BHP
ICT 1600W	16 000 MBH	14 960 MBH	447 BHP	14 080 MBH	420 BHP
ICT 1800W	18 000 MBH	16 830 MBH	503 BHP	15 840 MBH	473 BHP
ICT 2000W	20 000 MBH	18 700 MBH	559 BHP	17 600 MBH	525 BHP
ICT 2500W	25 000 MBH	23 375 MBH	698 BHP	22 000 MBH	657 BHP
ICT 2900W	29 000 MBH	27 115 MBH	810 BHP	25 520 MBH	762 BHP
ICT 3000W	34 000 MBH	31 790 MBH	950 BHP	29 920 MBH	894 BHP
ICT 3500W	38 000 MBH	35 530 MBH	1 061 BHP	33 440 MBH	1 000 BHP

**NOTES:**

**1. ABOVE CAPACITY RATINGS ARE BASED UPON THE FOLLOWING DESIGN CONDITIONS:**

- a) **Supply Water Temperature = 140°F**
- b) **Return Water Temperature = 110°F**
- c) **Oil Firing is non-condensing**

